

ITEM	PART NO.	DESCRIPTION	XP-2020	XP-2025	XP-2030	XP-2040	XP-2525	XP-2530	XP-2540	XP-3030	XP-3040	XP-4040
1	XPU01	PLATE, CROSSOVER, 1.9-3.5" X 1.9-3.5" OD	1	1	1	-	1	1	-	1	-	-
1	XPU02	PLATE, CROSSOVER, 1.9-4.5" X 1.9-4.5" OD	-	-	-	1	-	-	1	-	1	1
2	GUB4240	1/2"-13 UNC X 2-1/2" X 4" GALV U-BOLT	4	2	2	-	-	-	-	-	-	-
3	GUB4352	1/2"-13 UNC X 3" X 5-1/4" GALV U-BOLT	-	2	-	-	4	2	-	-	-	-
4	GUB4355	1/2"-13 UNC X 3-5/8" X 5" GALV U-BOLT	-	-	2	-	-	2	-	4	-	-
5	GUB52440	5/8"-11 UNC X 2-1/2" X 4" GALV U-BOLT	-	-	-	2	-	-	-	-	-	-
6	GUB5456	5/8"-11 UNC X 4-5/8" X 6-1/2" GALV U-BOLT	-	-	-	2	-	-	2	-	2	4
7	GUB53045	5/8"-11 UNC X 3" X 4-1/2" GALV U-BOLT	-	-	-	-	-	-	2	-	-	-
8	GUB53560	5/8"-11 UNC X 3-5/8" X 6" GALV U-BOLT	-	-	-	-	-	-	-	-	2	-

REVISIONS				
REV.	ZONE	DESCRIPTION	BY	DATE
A		INITIAL RELEASE	ACG	08/29/18

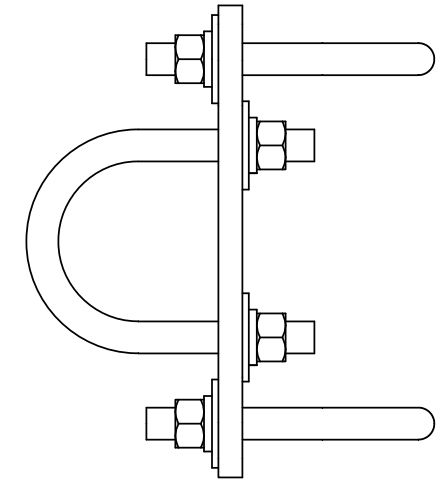
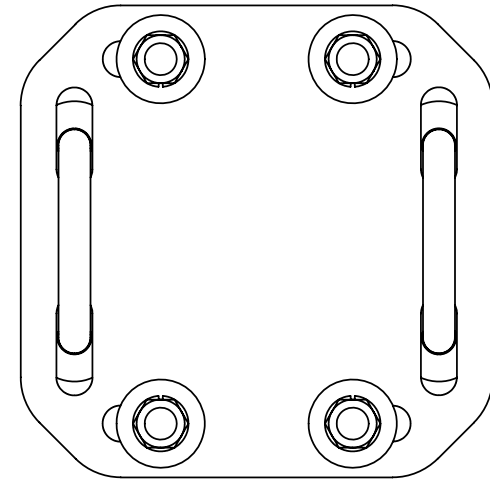
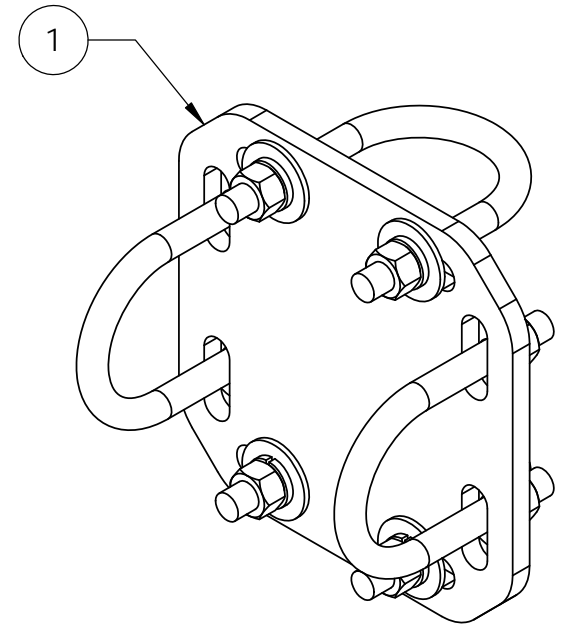
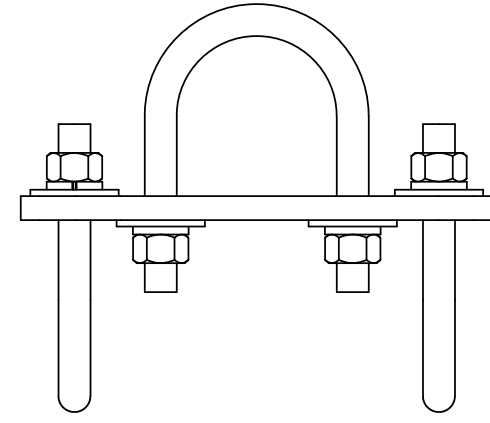

Part No.	Description	Weight
XP2020	CROSSOVER PLATE, 2-3/8" O.D. PIPE TO 2-3/8" O.D. PIPE	7.79 LBS
XP2025	CROSSOVER PLATE, 2-3/8" O.D. PIPE TO 2-7/8" O.D. PIPE	8.10 LBS
XP2030	CROSSOVER PLATE, 2-3/8" O.D. PIPE TO 3-1/2" O.D. PIPE	8.08 LBS
XP2040	CROSSOVER PLATE, 2-3/8" O.D. PIPE TO 4-1/2" O.D. PIPE	13.07 LBS
XP2525	CROSSOVER PLATE, 2-7/8" O.D. PIPE TO 2-7/8" O.D. PIPE	8.41 LBS
XP2530	CROSSOVER PLATE, 2-7/8" O.D. PIPE TO 3-1/2" O.D. PIPE	8.39 LBS
XP2540	CROSSOVER PLATE, 2-7/8" O.D. PIPE TO 4-1/2" O.D. PIPE	13.29 LBS
XP3030	CROSSOVER PLATE, 3-1/2" O.D. PIPE TO 3-1/2" O.D. PIPE	8.38 LBS
XP3040	CROSSOVER PLATE, 3-1/2" O.D. PIPE TO 4-1/2" O.D. PIPE	13.88 LBS
XP4040	CROSSOVER PLATE, 4-1/2" O.D. PIPE TO 4-1/2" O.D. PIPE	14.15 LBS

NOTES:
 1. ALL METRIC DIMENSIONS ARE IN BRACKETS.
 2. STAMP PART IDENTIFICATION NUMBER.

These drawings and specifications are proprietary property and may be used only for the specific purpose authorized in writing.	DRAWN BY: ACG	SHEET: 1 of 1	PART NUMBER: XP SERIES
	CHECKED BY: CC	SCALE: NTS	DESCRIPTION: CROSSOVER PLATE SERIES
	DATE: 08/29/18	MATERIAL: ASTM A36	DRAWING TYPE: ASSEMBLY DRAWING
	REVISION: A	FINISH: ASTM A123	WEIGHT: SEE TABLE
DO NOT SCALE THIS PRINT			